

# GASGUARD

## GAS PROVING & INTERLOCK SYSTEM



### | OVERVIEW |

The NEW GasGuard gas pressure proving system is designed to meet the requirements of IGEM/UP/11 for educational establishments and is a BS6173 and IGEM/UP/19 compliant ventilation interlock.

With a new stylish housing, negative display, and internal hinge system, the GasGuard looks at home in any new installation.

Along with a fresh new exterior, the GasGuard has also had a major internal overhaul and new user interface, with new menus to allow simple system setup, to view system status, and to access the data-logging function.

The GasGuard will allow the users to view the last 50 alarms through the panel display, and a full event log is also available when using the USB interface and Flamefast App, all supported by a real time clock.

### | KEY FEATURES |

- New stylish enclosure
- Clear negative display
- Optional BACnet/Modbus module
- Alarm and Event logs as standard
- 24VDC auxiliary power output
- Interfaces for:
  - Gas Sensors
  - CO2 Sensor
  - Ventilation Systems
  - Remote Emergency Stop Buttons
  - Fire Alarm System
- High accuracy Pressure Transmitter
- **5 Year Warranty**
- **UK MANUFACTURED**

### DIMENSIONS

Height	180mm
Width	180mm
Depth	65mm / 70mm including Stop & Key Switch

### TECHNICAL SPECIFICATION

Power Supply	85 ~ 300VAC 50/60Hz	
Power Consumption	20W Max (Panel Only)	
Outputs	Gas Solenoid	Switched Mains (5A Fused)
	Valve Status	SPST - 5A @ 250V Max
	BACnet MS/TP or Modbus RTU (with -COM)	
Operating Conditions	Temp	0 ~ 50°C
	Humidity	0 ~ 95% (NC)
IP Rating	IP65	
Housing Material	PC/ABS	
Colour	Pure White (RAL 9010)	
Approval	CE, UKCA	

### EXTERNAL DEVICE INTERFACES

Pressure Transmitter	PT00 Connection
24V Out	24V DC Power Out - 600mA (for TR, SS, FGS)
Gas Sensor	BACnet Interface for FGS Range
CO2 Sensor	LV Signal to monitor external VFC
Intake Fan	LV Signal to monitor external VFC
Extract Fan	LV Signal to monitor external VFC
Remote Stop	LV Signal to monitor external VFC
Fire Alarm	LV Signal to monitor external VFC

### INSTALLER SELECTABLE OPTIONS

Gas Proving Fill/Test Time	5s Fill + 30s Test / 10s Fill + 60s Test
Gas Availability Timer	Off / 4 / 8 / 16 Hours

### PART NUMBERS & COMMON ACCESSORIES

PART NO	DESCRIPTION
GG-PT00 -COM	GasGuard System c/w Pressure Transmitter +BACnet/Modbus Communication Module
TR-CO2TL	Transmitter - CO2 & Temp c/w LCD
ADPS	Air Differential Pressure Switch (20-300Pa) c/w Duct Kit
RSTOP-C	Remote Emergency Stop - Call Point
SVxx	XXmm Gas Solenoid Valve (230V) - Specify Size



# GASGUARD

**GAS PRESSURE PROVING & INTERLOCK SYSTEM**

Manufactured in the UK by



**Flamefast Controls Ltd**

**10 Ravenhurst Court**

**Birchwood**

**Warrington**

**WA3 6PN**

**T: 01925 281249**

**[sales@flamefastcontrols.co.uk](mailto:sales@flamefastcontrols.co.uk)**

**[www.flamefastcontrols.co.uk](http://www.flamefastcontrols.co.uk)**

# COMMISSIONING CHECKLIST TEMPLATE

## FLAMEFAST CONTROLS – GASGUARD

This checklist is to be completed by the installer and as a record of system commissioning (this is not manufacturer certification).

<b>SITE NAME</b>	
------------------	--

<b>SITE ADDRESS</b>	
<b>POST CODE</b>	
<b>ROOM REFERENCE</b>	
<b>PANEL MODEL</b>	
<b>SERIAL NO</b>	
<b>GAS PRESSURE</b>	

SYSTEM INSPECTION & OPERATION	YES	NO	
Panel wired as per diagram, including cable screening where applicable	<input type="radio"/>	<input type="radio"/>	
Display functioning correctly and clear to read	<input type="radio"/>	<input type="radio"/>	
Gas Solenoid Valve Opens and system completes pressure test	<input type="radio"/>	<input type="radio"/>	
System Passed Let-By Test (must be performed by a Gas Safe engineer)	<input type="radio"/>	<input type="radio"/>	
System Passed Tightness Test (must be performed by a Gas Safe engineer)	<input type="radio"/>	<input type="radio"/>	
System Detects open ends during pressure test (open outlet during)	<input type="radio"/>	<input type="radio"/>	

INTERFACE FUNCTIONALITY TEST	OK	FAIL	N/A
Key Switch operates correctly	<input type="radio"/>	<input type="radio"/>	
Panel Emergency Stop	<input type="radio"/>	<input type="radio"/>	
Remote Emergency Stop (multiple stops must be tested independently)	<input type="radio"/>	<input type="radio"/>	<input type="radio"/>
Ventilation Interlock (switch Intake and Extract fans off independently to prove)	<input type="radio"/>	<input type="radio"/>	<input type="radio"/>
CO2 Interlock shuts down system (take CO2 sensor over 4,500ppm)	<input type="radio"/>	<input type="radio"/>	<input type="radio"/>
Gas Sensors showing correctly and shut down system at Alarm 2	<input type="radio"/>	<input type="radio"/>	<input type="radio"/>

<b>COMMISSIONED BY</b>	
<b>COMPANY</b>	
<b>DATE</b>	
<b>SIGNATURE</b>	

# INSTALLATION

## GASGUARD

The information contained within this guide is to cover typical installations, however allowances must be made for the site-specific requirements. If in doubt always contact Flamefast for further guidance.

### TECHNICAL SPECIFICATION

Power Supply	85 – 300VAC 50/60Hz
Power Consumption	20W (Panel Only)
Gas Solenoid Output Rating	5A @ 250V Max
Status Relay Rating	5A @ 250V Max
Comms Output	See BACnet/Modbus Specification
Operating Conditions	Temp 0 - 50°C Humidity 0 - 95% (NC)
IP Rating	IP65
Housing Material	PC/ABS
Colour	Pure White (RAL 9010)
Approval	CE, UKCA

### IMPORTANT

#### READ CAREFULLY PRIOR TO INSTALLATION

- This product must be installed by a competent/qualified person in accordance with all relevant national and local regulations and legislations:
  - BS 6173
  - IGEM/UP/2
  - IGEM/UP/11
  - IGEM/UP/19
- If there is any question over the suitability for your application, contact Flamefast prior to installation.
- This product must be mounted flush to the wall (or similar) using secure fixings to prevent access to the rear.
- This product must be connected to an accessible 5A fused spur and ensure that the electrical rating of any components is not exceeded.
- Ensure the mains supply is isolated and locked off prior to installation.
- If this equipment is used in a manner not specified by the manufacturer, protection provided may be impaired.
- This product is designed for indoor use in ambient temperatures and standard atmospheric conditions.
- Following installation, the correct operation of the system and any associated items should be verified.
- All Gas Safety Systems should be safety checked by a competent/qualified person at least annually.

### PANEL LOCATION

The control panel should be mounted either next to the primary emergency exit or next to the teachers bench (where applicable). Any additional emergency exits should be fitted with a remote emergency stop button.

### PANEL MOUNTING

The control panel should be mounted at a readily accessible height (typically 1.2 – 1.5m from the finished floor level) ensuring that the panel mounted Emergency Stop Button is easily accessible.

For securing the panel to the wall there are four mounting holes, one in each corner; these should be used to ensure that the IP rating of the unit is not compromised.

With regards to cable entry, there are 3no 35mm knock outs in the rear of the panel which must be sealed if mounted externally. Cables can be brought in from the top or bottom however allowances for internal components must be made, and mains cables should not be run across the face of the PCB.

**ALWAYS REMOVE THE PCB PRIOR TO DRILLING THE ENCLOSURE OR REMOVING THE KNOCKOUTS TO AVOID DAMAGING THE PCB AND ENSURE ANY GLANDS CLEAR COMPONENTS PRIOR TO DRILLING**

### ELECTRICAL CONNECTIONS

All electrical connections are to be made as indicated on the wiring diagram (overleaf) and the maximum cable size should not be exceeded.

Any Volt Free interfaces (i.e. Remote Stop) must be wired using a dedicated volt free contact and where more than one device is used these MUST be wired in SERIES. Multiple panels cannot be wired to a single contact.

It is recommended that ALL devices connected to the low voltage terminals be done so using a screened cable as any voltage induction can cause fault conditions or in more severe cases, cause damage to the panel.

### 24V OUTPUT

The 24V DC auxiliary output is designed to power numerous Flamefast devices, however the maximum rating of 700mA should not be exceeded. The device consumptions are as below, however site-specific conditions and cable resistance should also be considered:

Description	Max Consumption
Flamefast Gas Sensor (FGS)	100mA
Transmitter/Smart Sensor (TR/SS)	50mA
Fan Current Monitor (FCMON)	40mA

The output can be increased to 2,000mA with the use of the Flamefast Boxed 24VDC Power Supply (PS-24D).

### GAS AVAILABILITY TIMER

The Gas Availability Timer is used to ensure the system is isolated at the end of each day. This can be set to 4, 8, 16 hours or disabled using a combination of DIP switches 3 and 4 (default 16 hours). No alarms will be raised, the system will simply fail to safe. This also ensures that the gas pipework is tested daily.

### GAS FILL & TEST TIME

DIP switch 1 can be used to increase the gas pipework pressurisation time from 5 to 10 seconds for larger volume systems. When the fill time is increased, this also increases the test time from 30 to 60 seconds.

When using a pressure switch instead of a transmitter, the test time will double.

### LCD MODE SELECT

The new range of panels (2026 onwards) use a Negative Mode display (White Text on a Black Background), whereas the older style panels (before 2026) use a Positive Mode display (Black Text on a White Background).

The LCD MODE jumper must be fitted for all new Negative type displays. Remove the link when using a Positive mode display.

#### Negative Mode

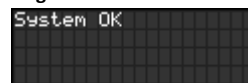

#### Positive Mode

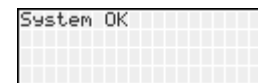

### USB INTERFACE

The USB-C interface can be used for the Flamefast Connect App to update the time and date, and can be used to customise certain parameters, including:

- Fill / Test Time for larger installations or higher sensitivity.
- Pressure Alarms (High, Low, Test Fail, Running Pressure Drop)
- Pressure Transmitter Settings & Gas Pressure

A full event log is also downloadable in CSV format, which will track all alarms and interface events.

### DATALOGGING & BATTERY BACKUP

The panel is fitted with a CR2032 coin cell battery to maintain the date and time in the event of a power loss. Removal will require the time to be reset using the Flamefast App (see App user guide for further details).

# GASGUARD CONNECTION DETAILS

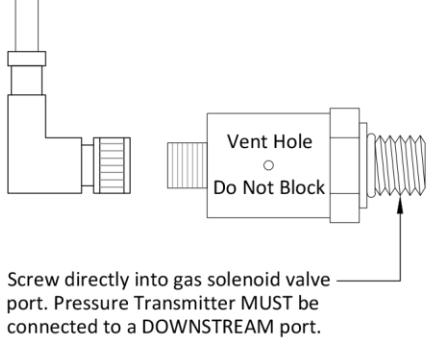
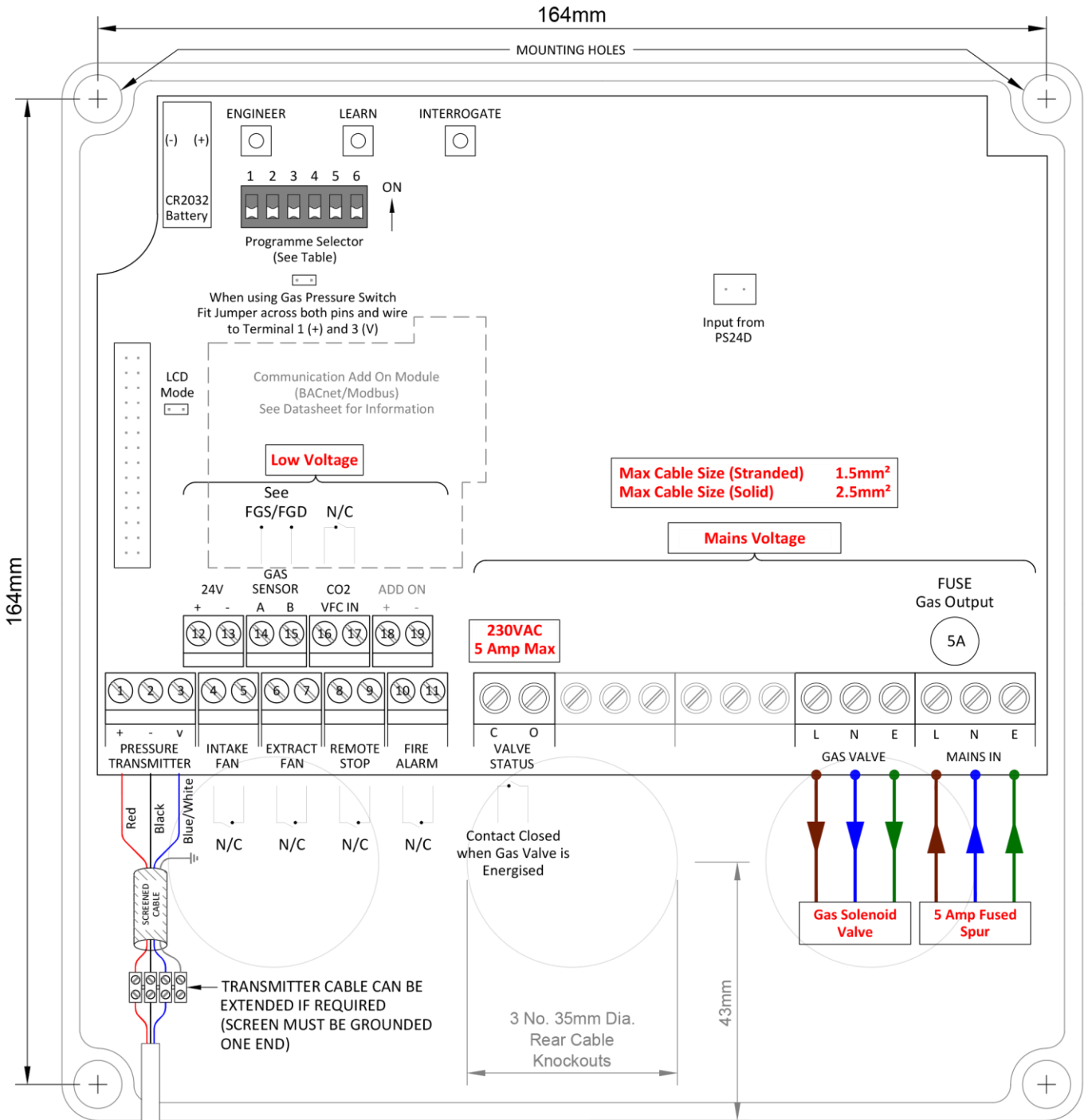

Programme Selector Options				
	OFF		ON	
DIP 1	Gas Fill 5s / 30s Test Time		Gas Fill 10s / 60s Test Time	
DIP 2	-		-	
DIP 3 & 4	Timer Automatically Shuts System Off After Set Number of Hours			
	16 Hours	4 Hours	8 Hours	Timer Disabled
DIP 5	-		-	
DIP 6	-		-	

# ADPS / RSTOP / FIRE

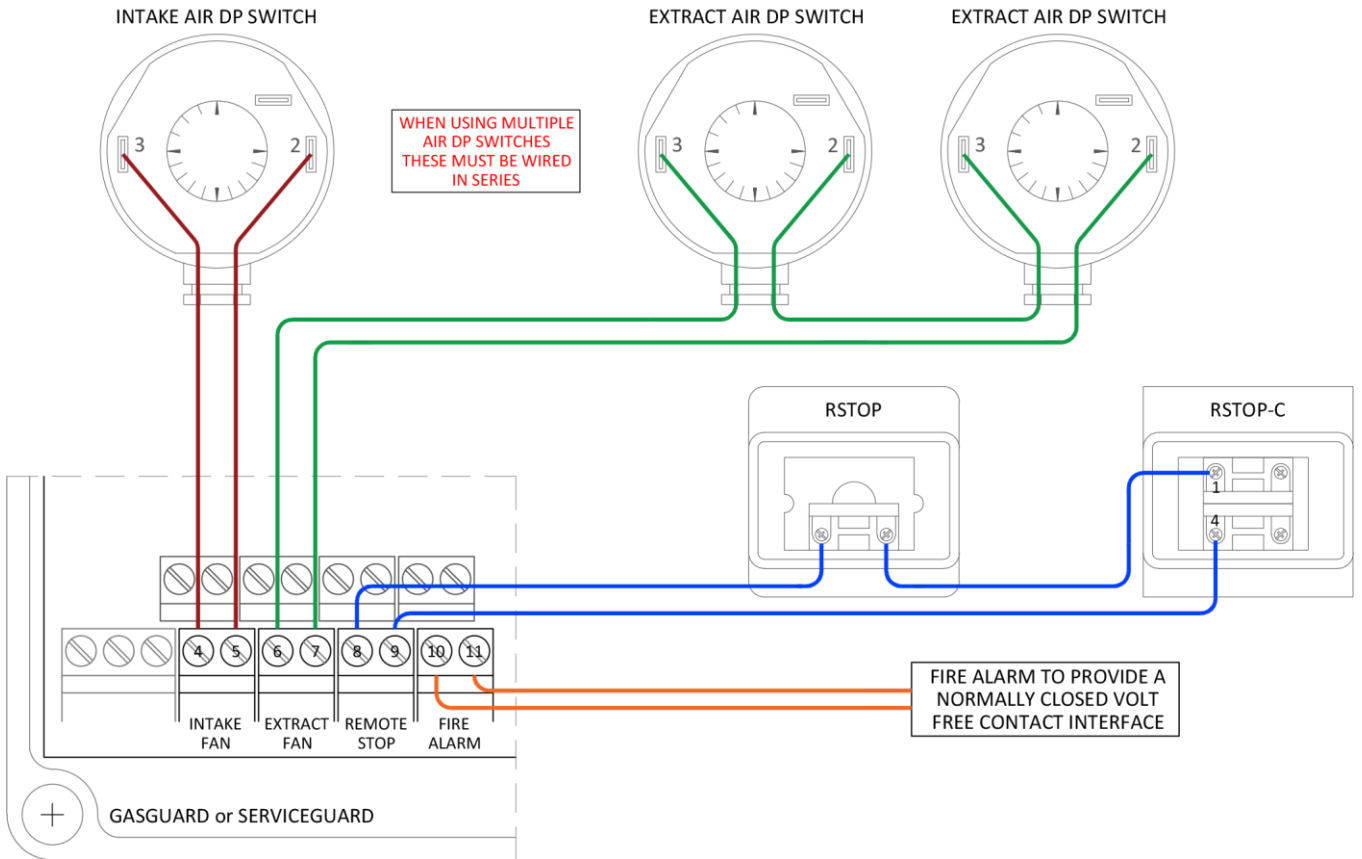

## TR-CO2TL

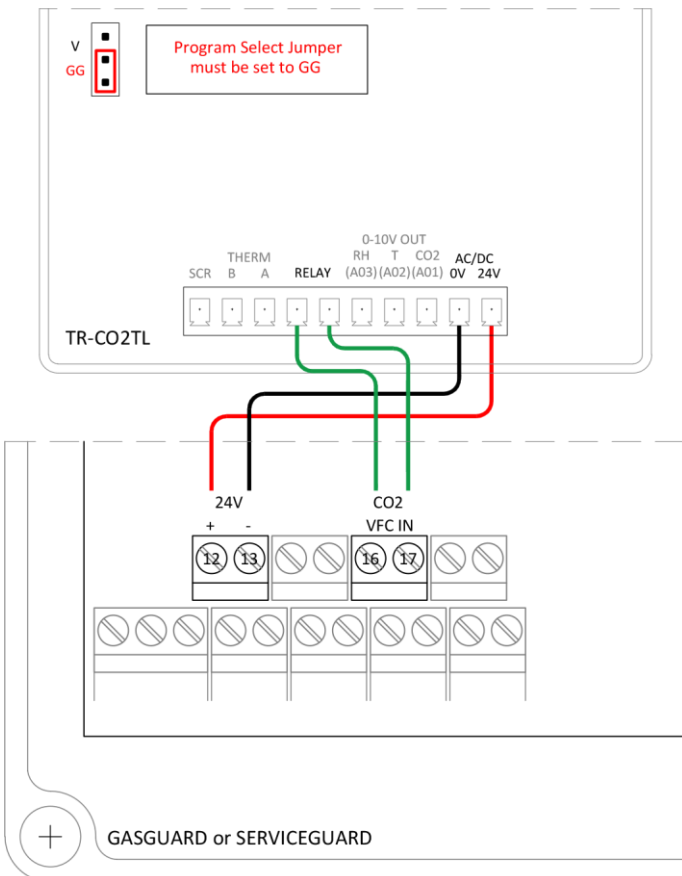

## CO2M

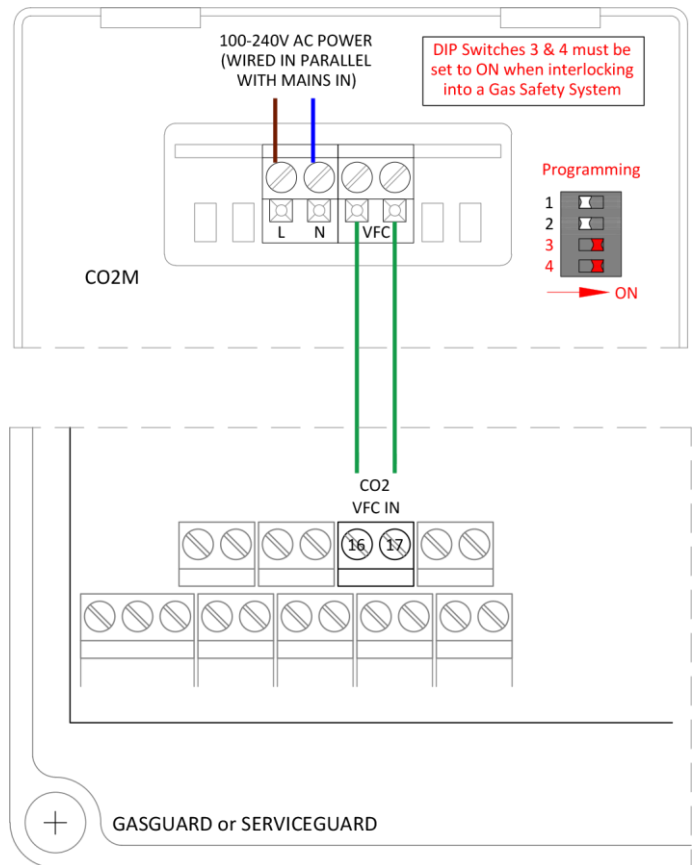

# GAS SENSORS

SEE BELOW CONNECTIONS WHEN CONNECTING TO THE PANEL

**SENSORS MUST BE WIRED IN ONE CONTINUOUS DAISY CHAIN. STAR WIRING CONFIGURATIONS MAY CAUSE THE PANEL TO 'LOSE' SENSORS**

**ALL SENSORS MUST BE SET TO DIFFERENT ADDRESSES, AND WE RECOMMEND NUMBERING STARTING AT 1, 2.. IN THE ORDER THEY ARE WIRED FROM THE PANEL**

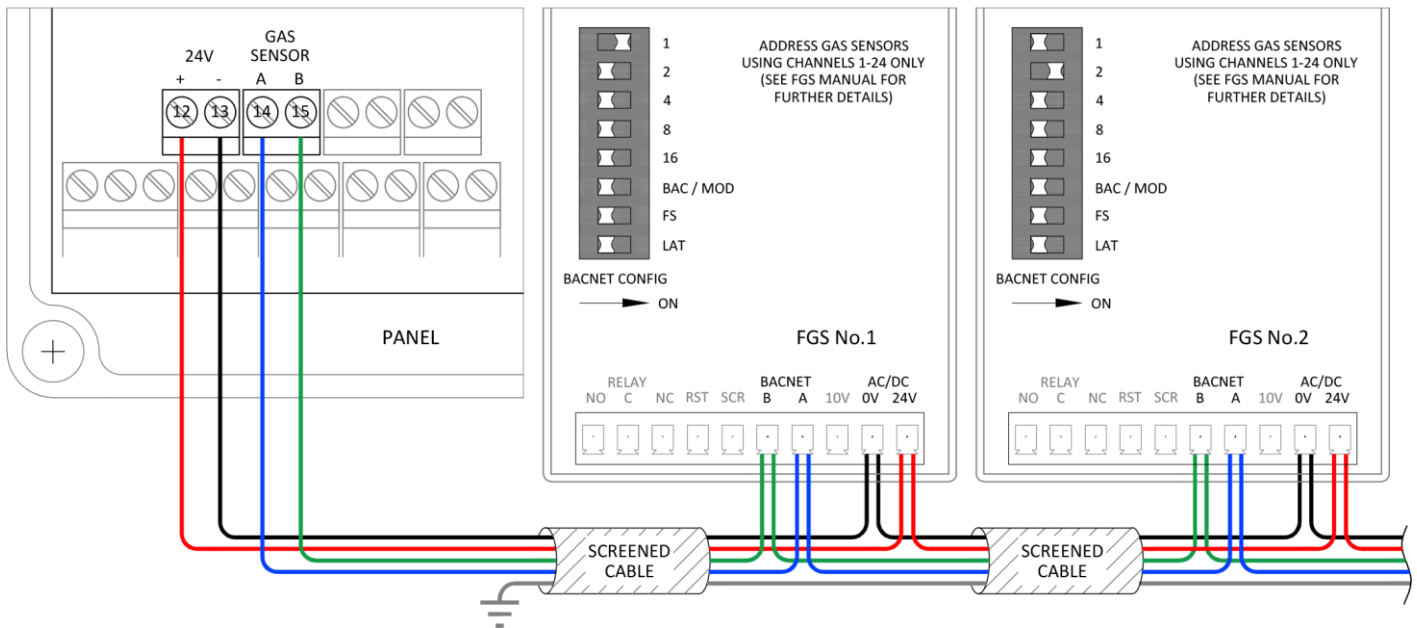

## BASIC OPERATION GASGUARD

### SYSTEM PRINCIPLE

The GasGuard system is designed to provide a pressure test of the gas pipework system prior to restoration of the gas supply following an emergency shutdown.

If there is an open end, this will cause a drop in gas pressure that will be picked up during the test. Whilst the requirement of IGEM/UP/11 is to detect "open ends", due to the accuracy of the pressure transmitter, small leaks on the pipework can also be detected.

For larger installations, or where further accuracy is required, the test parameters can be adjusted using the Flamefast Connect App.

### OPERATION

Clear instructions on the use of the system and details of any faults are provided by the LCD readout.

Daily use:

1. To request gas, turn the Key to ON which will initiate the pressure test.
  - a. The valve will open for 5 seconds to pressurise the pipework.
  - b. A pressure measurement will be taken.
  - c. The pressure will be monitored for a drop over 30 seconds.
  - d. If a pressure drop of more than 5% of the initial test pressure is detected, the panel will alarm and advise on the severity of the leak.
  - e. If no pressure drop is detected, the panel will open the gas valve.
2. Turn the key to OFF to switch off the gas supply.

**THE KEY SWITCH SHOULD BE TURNED TO THE OFF POSITION  
AND THE KEY REMOVED WHEN THE ROOM IS UNOCCUPIED**

## FLAMEFAST CONNECT APP GASGUARD

The Flamefast Connect App allows for setup and customisation of a wide range of intelligent Flamefast products, including the GasGuard.

PARAMETER	DEFAULT	UNIT	MIN	MAX
<b>PRESSURE SETTINGS</b>				
Pressure Units	mBar		mB / kP	
Fill Time	5	seconds	1	60
Test Time	30	seconds	10	300
Acceptable Drop	5.00	%	0.05	50.00
Running Pressure Drop (Set to % as default)	50.00	%	0.05	90.00
	15.00	mBar	1.00	50000.00
Running Pressure Drop Time	5	seconds	1	60
Transmitter Range Min	1.00	V	0.00	5.00
Transmitter Range Max	5.00	V	0.00	5.00
Transmitter Fault Alarm	0.50	V	0.00	5.00
Pressure Range Min	0	mBar	0	50000
Pressure Range Max	100	mBar	0	50000
No Pressure Alarm	1	mBar	0	50000
Low Pressure Alarm	15	mBar	0	50000
High Pressure Alarm	70	mBar	0	50000
<b>TIMER SETTINGS</b>				
Gas Availability 1, 2, 3 & 4	--	hours	0.25	168.00

# SYSTEM SETUP

## GASGUARD

Inside the panel at the top of the rear PCB there are three buttons for use during Setup and Commissioning. The main functions include:

- **ENGINEER** Gas Valve / Pressure fault diagnosis, and Tightness Test.
- **LEARN** Setup and View connected Gas Sensors.
- **INTERROGATE** View system status and Fault Log.

Press the **↑ / ENTER / ↓** buttons on the front of the panel to navigate menus.

### ENGINEER

The ENGINEER button can be used to aid with gas and pressure related issues and fault diagnosis.

Providing the Remote Stop Button interface is not open circuit, holding the ENGINEER button whilst turning the key-switch to ON will force the Gas Valve and Status relays open for 60 seconds (the button can be released once the key is turned). During this time, checks can be made:

- Power from the panel to the Gas Valve
- Power at the Gas Valve
- Pressure reading relative to the measured line pressure.

1. The timer will countdown from 60, whilst the line gas pressure will be displayed.



2. Once the 60 second timeout is complete, the panel will perform a 180 second (3-minute) tightness test (for indication only).



3. After 3 minutes the panel will display the Live pressure, Starting Pressure, and Pressure Drop over the 3 minutes.



### INTERROGATE (DATALOGGING)

The panel has Alarm datalogging included as standard, and will store the most recent 50 alarm events, each with a Date and Time stamp, with a real time clock based on Coordinated Universal Time (UTC) that is maintained by the CR2032 battery in the event of loss of power.

The datalogging and system status menu can be entered one of two ways:

- Pressing the INTERROGATE button
- Holding the GAS button whilst the Key Switch is OFF.

1. Shows Date & Time.  
To update, connect to the Flamefast Connect App or Press Enter to adjust locally.

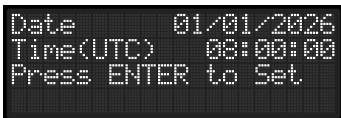

When factory set, the time will always display in Coordinated Universal Time (UTC). If the time is adjusted in the field, the "(UTC)" indication will no longer be displayed.

2. Provides the live downstream gas pressure and status of all inputs:  
OK = Healthy  
-- = Alarm



3. Days until a service is due, and if Gas Sensors are installed, days until the soonest sensor is due a calibration and replacement.



4. Alarm Event log with a Date & Time stamp. The description will be as per Line 1 of the display during an alarm condition.

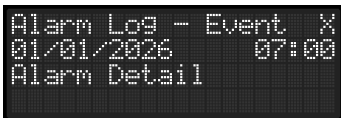

### LEARN

Following the installation of any Gas Sensors, they must be paired with the panel, which is done by pressing the LEARN button to enter a menu that will allow the sensors to be viewed and stored into the panel.

#### Setup

Is used to view and SAVE the number of sensors connected to the panel.



1. Shows the number of Sensors/Repeaters the panel is seeing – if correct, this matches what is installed, select SAVE.



2. Once SAVE is selected, the panel will confirm that the new configuration has been saved.



#### View Sensors

Overview of what channels are populated, and details of the sensor type and config for each channel.

1. If a sensor channel is populated, the channel number will show in the corresponding position.

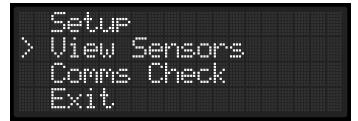

Example shown for 7 sensors using channels 1, 2, 3, 4, 9, 11 and 24.



Unpopulated channels show as "--".

2. Subsequent displays will show for each channel:

- Channel Number
- Gas Type
- Live Reading
- Unit of Measurement
- Days until Calibration due
- Days until Replacement due.



#### Comms Check

Performs a sensor comms check. Poor comms can result in nuisance alarms and highlight install issues.

1. Will show which channels are populated as shown in the View Sensors menu.

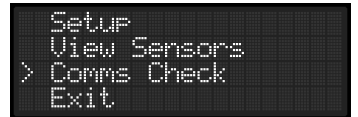

2. Each channel will briefly display 01 following a read request. If a response is received it will revert back to 00.



3. If a sensor fails to respond, the numbers will count failures, with this screen latching on the peak number of requests.



4. Used to adjust the amount of time before the panel flags a "Sensor Not Found" alarm.

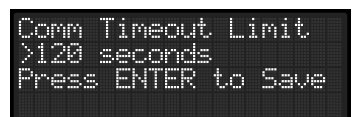

# TROUBLESHOOTING & MAINTENANCE

## GASGUARD

### TROUBLESHOOTING

Any faults can be easily identified due to the clear LCD readout. The following table provides details of all faults including effects and causes:

Display Line 1	Display Line 2	Interface	Cause	Isolates Gas
Previous Power Loss			Previous interruption in mains supply	-
Transmitter Fault	Call Engineer	Pressure Transmitter	Pressure Transmitter Input less than 0.50V	✓
No Incoming Pressure	Call Engineer XX.XmB	Pressure Transmitter	Pressure less than 1mB	✓
Low Gas Pressure	Call Engineer XX.XmB	Pressure Transmitter	Pressure less than 15mB	✓
High Gas Pressure	Call Engineer XX.XmB	Pressure Transmitter	Pressure above 70mB	✓
XXmB Drop in XXXsec	Check Outlets	Pressure Transmitter	If pressure test sees a drop of more than 5%	✓
Pressure Loss	Call Engineer XX.XmB	Pressure Transmitter	Pressure drops by 50% for more than 5 seconds during operation	✓
Fire Alarm Active	Please Reset	Fire Alarm	Fire Alarm interface open circuit	✓
Remote Stop Pressed	Please Reset	Remote Stop	Remote Stop interface open circuit	✓
Panel Stop Pressed		Panel Stop	Panel Stop pressed	✓
High CO2 Levels	Ventilate Room	CO2 VFC In	CO2 interface open circuit	✓
Intake Fan Fail	Check Operation	Intake Fan	Intake interface open circuit	✓
Extract Fan Fail	Check Operation	Extract Fan	Extract interface open circuit	✓
New Sensor Added	Press LEARN to Setup	Gas Sensor	FGD/FGS – New sensor found on network	✓
Sensor Not Found	Call Manufacturer	Gas Sensor	FGD/FGS – Sensor lost on network	✓
Sensor Error	Call Manufacturer	Gas Sensor	FGD/FGS – Sensor Error	✓
Calibration Due	Call Manufacturer	Gas Sensor	FGD/FGS – Sensor Calibration Due within 30 days	-
New Sensor Required	Call Manufacturer	Gas Sensor	FGD/FGS – Sensor requires replacement within 30 days	-
Replace Sensor	Call Manufacturer	Gas Sensor	FGD/FGS – Sensor requires immediate replacement	✓
Alarm Level 1	Channel XX	Gas Sensor	FGD/FGS – Sensor in Alarm 1 condition	-
Alarm Level 2	Channel XX	Gas Sensor	FGD/FGS – Sensor in Alarm 2 condition	✓

### PRESSURE TRANSMITTER

The high accuracy Pressure Transmitter is used to monitor the gas pressure and provides a 0-100mBar output, scaled over 1-5VDC.

Transmitter Fault indicates that the panel is receiving less than 0.5V from the transmitter. To check the functionality:

- Check there is 24VDC across terminals 1 and 2 at the panel.
- Check there is 24VDC on the corresponding cables at the sensor.
- Check the voltage across terminals 2 and 3.

If the transmitter does not respond to any pressure changes, this is more than likely due to a blockage of the internal pressure vent. This is either on the side of the transmitter body, or at the end of the pre-wired cable. This **MUST** be left open to atmosphere.

If the transmitter appears to be functioning correctly, however does not respond to a drop in pressure, ensure that it is installed into a downstream port (refer to the valve manufacturer documentation for port configuration) and that the valve is installed in the correct orientation.

### GAS SENSORS

Prior to connection of any gas sensors, ensure that each core (24V, 0V, A and B) is independent, and there is no external or induced voltage as this can cause data corruption, and in some cases, irreparable damage to the sensor.

Any damaged sensors or address conflicts may result in multiple sensors not displaying on the system, including those that are otherwise functioning.

### GAS VALVE OUTPUT

If the panel appears to be operating correctly but there is no output to the Gas Valve, check that the PCB mounted radial fuse is still intact. This is located just above the mains in terminals (see wiring diagram for details).

### LCD

If the LCD is displaying random characters (as below) there has been a breakdown in communication between the Main PCB and the LCD. There are a number of ways to reset the display when this occurs:



1. Power cycle panel at fused spur.
2. With the Key Switch OFF:
  - a. Hold GAS button for 5 seconds
  - b. Press INTERROGATE button.

The display will also automatically refresh itself at 6am and 6pm daily.

### CO2 SENSORS

CO2 sensors should display 400ppm in outdoor air. However, they are susceptible to contamination from fine dusts or cleaning solvents which can distort the infra-red optics. 'Poisoning' of the sensor may cause it to display a high reading.

In such instances, power cycle the sensor momentarily, then leave continuously powered for 24 hours, after which the sensor will automatically recalibrate.

**Sensor should see outdoor CO2 levels for at least 2 hours every 7 days.**

### MAINTENANCE

The system requires a safety check at least annually to ensure the correct operation of the panel and all associated interlocks.

Any connected gas sensors should be bump tested following installation and calibrated at least annually.

This should be carried out by a FLAMEFAST APPROVED ENGINEER.

The service shall be by a Gas Safe Registered Engineer as tightness and let-by test must be performed to prove the correct operation of the solenoid valve.