

GASMONITOR

16 CHANNEL GAS DETECTION SYSTEM



| OVERVIEW |

The New GasMonitor is a low cost, high specification Gas Detection controller for Laboratory installations in Universities, Hospitals and Research Facilities.

With an aesthetically pleasing housing, the ability to monitor up to 24 Flamefast Gas Sensors and relay outputs for remote monitoring or beacon activation, the GasMonitor is a self-contained system suitable for most laboratory installations, whilst the optional BACnet/Modbus interface module allows multiple panels to be easily integrated with the onsite BMS.

The addition of data logging provides the last 50 alarm conditions through the user interface, with a full even log available through the USB connection.

| KEY FEATURES |

- New Stylish Enclosure
- Selectable Ventilation Control Mode
- Auto-reset following Fire Alarm
- Auto-reset following Power Failure
- Optional BACnet/Modbus module
- 24VDC auxiliary power output
- Interfaces for:
 - Thermal Links
 - Ventilation Systems
 - Remote Emergency Stop Buttons
 - Fire Alarm Systems
- Remote reset interface
- Relays for Alarm 1, Alarm 2, and Fault
- **5 Year Warranty**
- **UK MANUFACTURED**

DIMENSIONS

Height	180mm
Width	180mm
Depth	65mm

TECHNICAL SPECIFICATION

Power Supply	85 ~ 300VAC 50/60Hz
Power Consumption	20W Max (Panel Only)
Outputs	Gas Solenoid Switched Mains
	Alarm 1 SPDT - 5A @ 250V Max
	Alarm 2 SPDT - 5A @ 250V Max
	Fault SPST - 5A @ 250V Max
	BACnet MS/TP or Modbus RTU (with -COM)
Operating Conditions	Temp 0 ~ 50°C
	Humidity 0 ~ 95% (NC)
IP Rating	IP65
Housing Material	PC/ABS
Colour	Pure White (RAL 9010)
Approval	CE, UKCA

EXTERNAL DEVICE INTERFACES

24V Out	24V DC Power Out - 600mA (for TR, SS, FGS)
Gas Sensor	BACnet Interface for Gas Sensor
Ventilation	LV Signal to monitor external VFC
Thermal Link	LV Signal to monitor external VFC
Fire Alarm	LV Signal to monitor external VFC
Remote Stop	LV Signal to monitor external VFC
Remote Reset	LV Signal to monitor Momentary Switch

INSTALLER SELECTABLE OPTIONS

Ventilation Mode	ON / OFF
Fire Alarm Auto-reset	ON / OFF
Power Failure Auto-reset	ON / OFF

PART NUMBERS & COMMON ACCESSORIES

PART NO	DESCRIPTION
GM-PO -COM	GasMonitor Panel +BACnet/Modbus Communication Module
FGS-O2	Flamefast Gas Detector - Oxygen
FGS-CO2	Flamefast Gas Detector - Carbon Dioxide
AVT24G	Traffic Light Alarm Indicator - Grey
CABLE1	Belden 8723 Equivalent (100m)



GASMONITOR

GAS DETECTION SYSTEM (24 CHANNEL)

Manufactured in the UK by



Flamefast Controls Ltd
10 Ravenhurst Court
Birchwood
Warrington
WA3 6PN
T: 01925 281249

sales@flamefastcontrols.co.uk
www.flamefastcontrols.co.uk

COMMISSIONING CHECKLIST TEMPLATE

FLAMEFAST CONTROLS – GASMONITOR

This checklist is to be completed by the installer and as a record of system commissioning (this is not manufacturer certification).

SITE NAME	
------------------	--

SITE ADDRESS	
POST CODE	
ROOM REFERENCE	
SERIAL NO	

SYSTEM INSPECTION & OPERATION	YES	NO	N/A
Panel wired as per diagram, including cable screening where applicable	<input type="radio"/>	<input type="radio"/>	
Display functioning correctly and clear to read	<input type="radio"/>	<input type="radio"/>	
Alarm 1 Set to Latching	<input type="radio"/>	<input type="radio"/>	<input type="radio"/>
Alarm 2 Set to Latching	<input type="radio"/>	<input type="radio"/>	<input type="radio"/>
Panel Mode Selected	Gas Detection / Ventilation Control		
Power Auto-reset Enabled	<input type="radio"/>	<input type="radio"/>	
Fire Alarm Auto-reset Enabled	<input type="radio"/>	<input type="radio"/>	

INTERFACE FUNCTIONALITY TEST	OK	FAIL	N/A
Remote Emergency Stop (multiple stops must be tested independently)	<input type="radio"/>	<input type="radio"/>	<input type="radio"/>
Ventilation Interlock (switch Intake and Extract fans off independently to prove)	<input type="radio"/>	<input type="radio"/>	<input type="radio"/>
Fire Alarm Interface	<input type="radio"/>	<input type="radio"/>	<input type="radio"/>
Thermal Fusible Links	<input type="radio"/>	<input type="radio"/>	<input type="radio"/>
Gas Sensors showing correctly and shut down system at Alarm 2	<input type="radio"/>	<input type="radio"/>	<input type="radio"/>

CHANNEL	1	2	3	4	5	6	7	8	9	10	11	12
Gas Type												
Bump Tested												

CHANNEL	13	14	15	16	17	18	19	20	21	22	23	24
Gas Type												
Bump Tested												

COMMISSIONED BY	
COMPANY	
DATE	
SIGNATURE	

INSTALLATION

GASMONITOR

The information contained within this guide is to cover typical installations, however allowances must be made for the site-specific requirements. If in doubt always contact Flamefast for further guidance.

TECHNICAL SPECIFICATION

Power Supply	85 – 300VAC 50/60Hz
Power Consumption	20W (Panel Only)
Gas Solenoid Output Rating	5A @ 250V Max
Alarm 1 Relay Rating	5A @ 250V Max
Alarm 2 Relay Rating	5A @ 250V Max
Fault Relay Rating	5A @ 250V Max
Comms Output	See BACnet/Modbus Specification
Operating Conditions	Temp 0 - 50°C
	Humidity 0 - 95% (NC)
IP Rating	IP65
Housing Material	PC/ABS
Colour	Pure White (RAL 9010)
Approval	CE, UKCA

IMPORTANT

READ CAREFULLY PRIOR TO INSTALLATION

- This product must be installed by a competent/qualified person in accordance with all relevant national and local regulations and legislations:
 - IGEM/UP/2
 - IGEM/UP/11
- If there is any question over the suitability for your application, contact Flamefast prior to installation.
- This product must be mounted flush to the wall (or similar) using secure fixings to prevent access to the rear.
- This product must be connected to an accessible 5A fused spur and ensure that the electrical rating of any components is not exceeded.
- Ensure the mains supply is isolated and locked off prior to installation.
- If this equipment is used in a manner not specified by the manufacturer, protection provided may be impaired.
- This product is designed for indoor use in ambient temperatures and standard atmospheric conditions.
- Following installation, the correct operation of the system and any associated items should be verified.
- All Gas Safety Systems should be safety checked by a competent/qualified person at least annually.

PANEL LOCATION

The control panel should be mounted in a readily accessible location, typically next to the emergency exit, on or adjacent to the BMS panel. Any additional emergency exits should be fitted with a remote emergency stop button.

PANEL MOUNTING

The control panel should be mounted at a readily accessible height (typically 1.2 – 1.5m from the finished floor level) ensuring that the panel mounted Emergency Stop Button is easily accessible.

For securing the panel to the wall there are four mounting holes, one in each corner; these should be used to ensure that the IP rating of the unit is not compromised.

With regards to cable entry, there are 3no 35mm knock outs in the rear of the panel which must be sealed if mounted externally. Cables can be brought in from the top or bottom however allowances for internal components must be made, and mains cables should not be run across the face of the PCB.

ALWAYS REMOVE THE PCB PRIOR TO DRILLING THE ENCLOSURE OR REMOVING THE KNOCKOUTS TO AVOID DAMAGING THE PCB AND ENSURE ANY GLANDS CLEAR COMPONENTS PRIOR TO DRILLING

ELECTRICAL CONNECTIONS

All electrical connections are to be made as indicated on the wiring diagram (overleaf) and the maximum cable size should not be exceeded.

Any Volt Free interfaces (i.e. Remote Stop) must be wired using a dedicated volt free contact and where more than one device is used these MUST be wired in SERIES. Multiple panels cannot be wired to a single contact.

It is recommended that ALL devices connected to the low voltage terminals be done so using a screened cable as any voltage induction can cause fault conditions or in more severe cases, cause damage to the panel.

24V OUTPUT

The 24V DC auxiliary output is designed to power numerous Flamefast devices, however the maximum rating of 700mA should not be exceeded. The device consumptions are as below, however site-specific conditions and cable resistance should also be considered:

Description	Max Consumption
Flamefast Gas Sensor (FGS)	100mA
Transmitter/Smart Sensor (TR/SS)	50mA

The output can be increased to 2,000mA with the use of the Flamefast Boxed 24VDC Power Supply (PS-24D).

VENTILATION CONTROL MODE

The GasMonitor has the option to operate in a Ventilation Control Mode. This will disable the audible alarm on the panel, and alarm relays will automatically reset following activation to allow the panel to provide multiple stage fan speed control.

A run on timer (1 or 5 minutes selectable) is in place to stop the fan motors burning out.

POWER & FIRE ALARM AUTO-RESET

The system can auto-reset following a power failure or fire alarm to ensure plant is able to restart when power is restored or fire alarm test complete and avoid any downtime due to loss of heating or hot water.

These functions are enabled as default and can be switched off using DIP switches 3 and 4 – a risk assessment should be carried out when using these functions.

THE STARTUP OF ALL PLANT SHOULD BE INTERLOCKED WITH THE FAULT RELAY

LCD MODE SELECT

The new range of panels (2026 onwards) use a Negative Mode display (White Text on a Black Background), whereas the older style panels (before 2026) use a Positive Mode display (Black Text on a White Background).

The LCD MODE jumper must be fitted for all new Negative type displays. Remove the link when using a Positive mode display.

Negative Mode

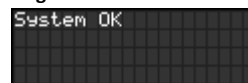

Positive Mode

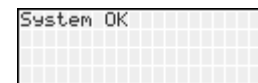

USB INTERFACE

The USB-C interface can be used for the Flamefast Connect App to update the time and date, and can be used to customise certain parameters, including the Alarm relay configurations.

A full event log is also downloadable in CSV format, which will track all alarms and interface events.

DATALOGGING & BATTERY BACKUP

The panel is fitted with a CR2032 coin cell battery to maintain the date and time in the event of a power loss. Removal will require the time to be reset using the Flamefast App (see App user guide for further details).

GASMONITOR CONNECTION DETAILS

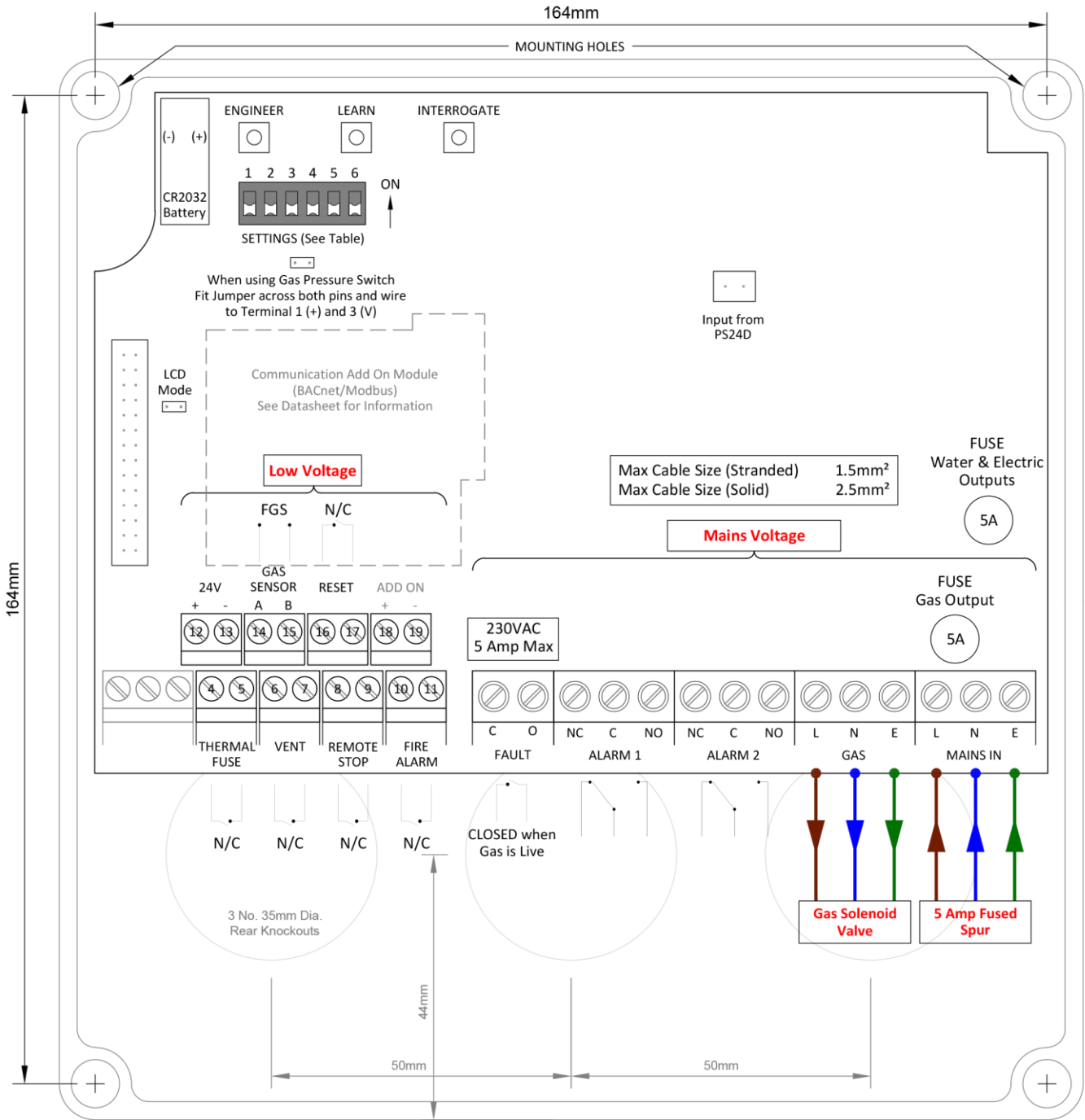

Programme Selector Options		
	OFF	ON
DIP 1	Gas Detection Mode	Vent Control Mode
DIP 2	Relay Run On - 1 Minute	Relay Run On - 5 Minutes
DIP 3	Power Loss Auto Reset ON	Power Loss Auto Reset OFF
DIP 4	Fire Alarm Auto Reset ON	Fire Alarm Auto Reset OFF
DIP 5	-	-
DIP 6	-	-

TFL / ADPS / RSTOP / FIRE

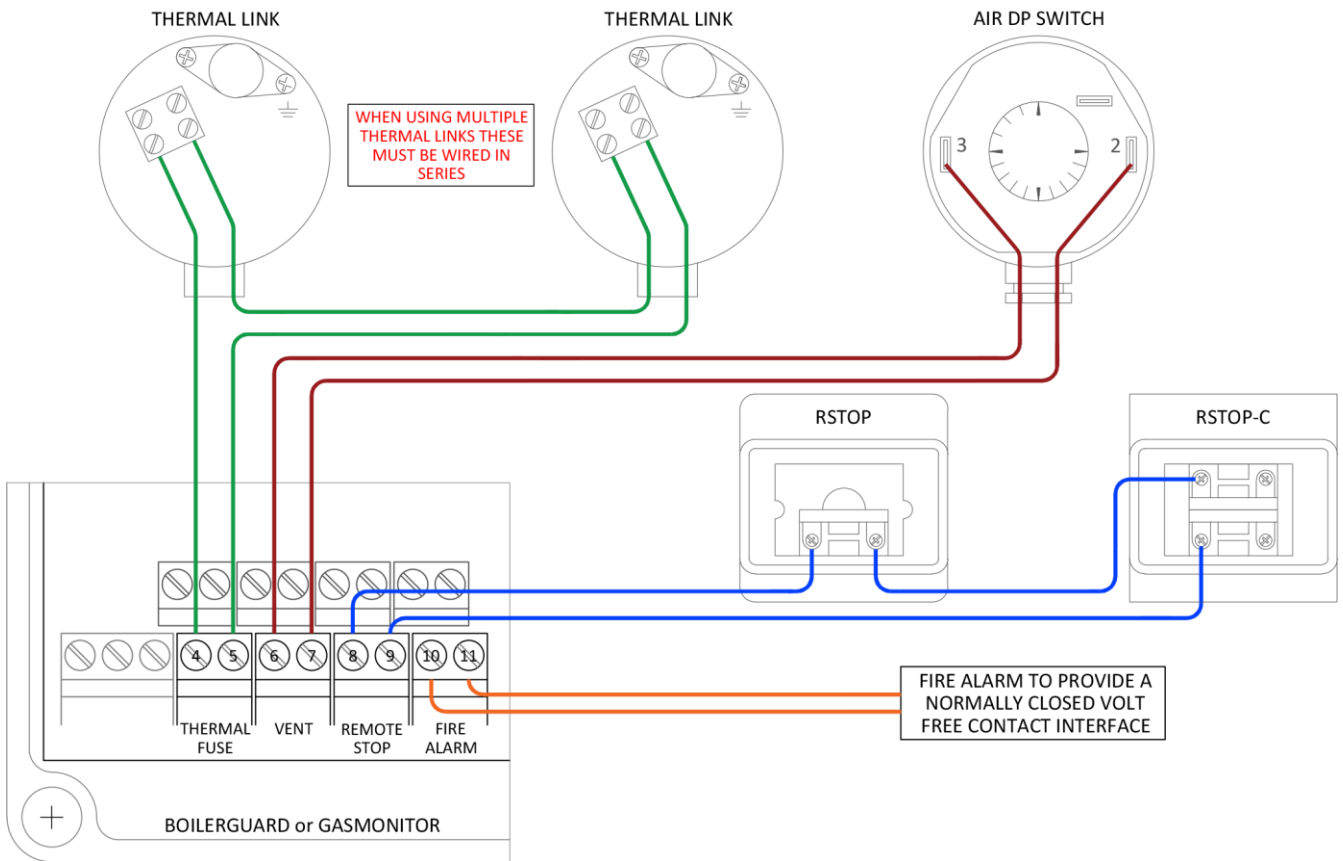

AVT (FULL TRAFFIC LIGHT)

REMOTE RESET

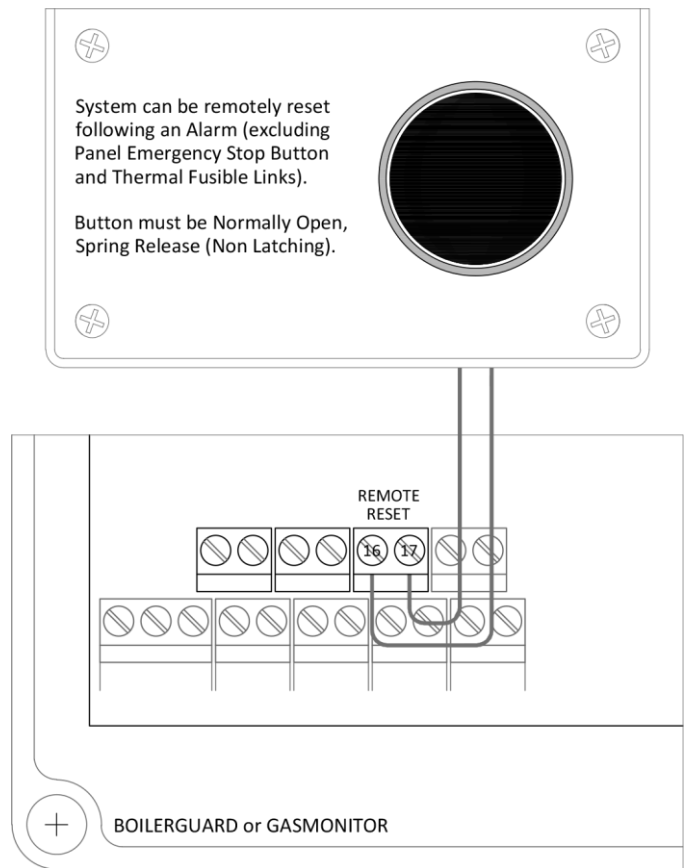
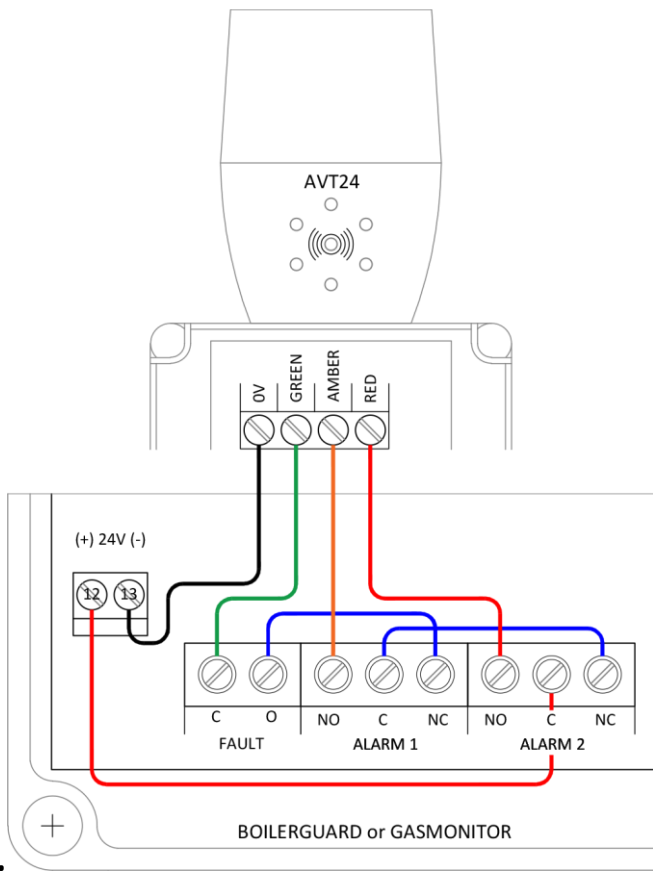

GAS SENSORS

SEE BELOW CONNECTIONS WHEN CONNECTING TO THE PANEL

**SENSORS MUST BE WIRED IN ONE CONTINUOUS DAISY CHAIN. STAR WIRING CONFIGURATIONS MAY CAUSE THE PANEL TO 'LOSE' SENSORS
ALL SENSORS MUST BE SET TO DIFFERENT ADDRESSES, AND WE RECOMMEND NUMBERING STARTING AT 1, 2.. IN THE ORDER THEY ARE WIRED FROM THE PANEL**

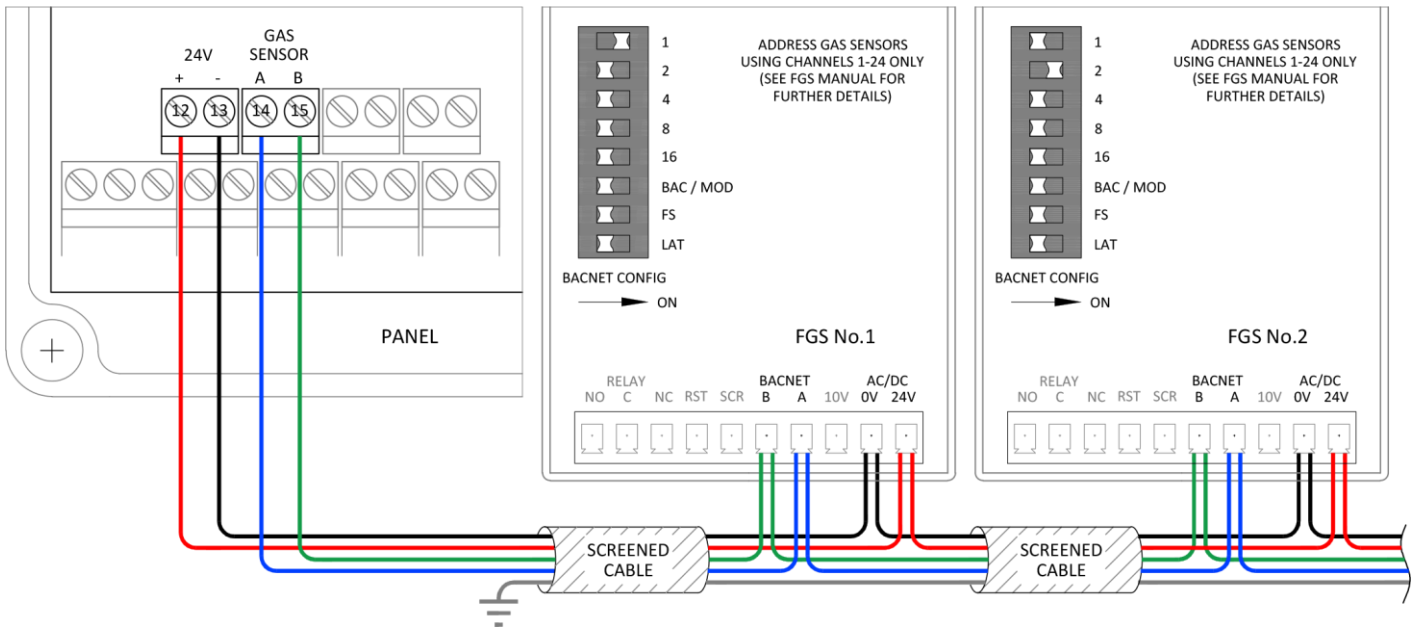

BASIC OPERATION GASMONITOR

SYSTEM PRINCIPLE

The GasMonitor system is designed as a general gas detection system for Laboratories and Car Parks, providing a central interface for other common interlocks such as thermal links and fire alarm systems.

OPERATION

Clear instructions on the use of the system and details of any faults are provided by the LCD readout.

On power up, the unit has a 90 second start up sequence. This is to allow any connected gas sensors to complete their own 60 second start up sequence.

Following the activation of any gas sensor alarms, the associated relay will energise to drive local audible/visual alarms or provide remote indication to a BMS or similar system.

Alarm relays can be set to Latching or Non-latching (depending on the specific applications), and relay delay and run on timers can be configured with the Flamefast Connect App.

REMOTE RESET

The system can be remotely reset by wiring a Normally Open, spring release push button in the Reset terminals. When pulsed, this will simulate the MUTE and RESET buttons being pressed sequentially, and will reset the panel providing any alarms have cleared.

This can also be remotely reset over a network when using the Add On Module.

THE SYSTEM WILL NOT RESET FOLLOWING A THERMAL LINK ACTIVATION AS THESE ARE NON-LATCHING DEVICES

FLAMEFAST CONNECT APP (COMING SOON)

The Flamefast Connect App allows for setup and customisation of a wide range of intelligent Flamefast products, including the GasMonitor.

PARAMETER	DEFAULT	UNIT	MIN	MAX
RELAY SETTINGS				
Alarm 1 Relay Latching	Off		Off / On	
Alarm 1 Relay Energised	Off			
Alarm 1 Relay Activation Delay	0	seconds	0	1800
Alarm 1 Relay Run On Timer	0	seconds	0	1800
Alarm 2 Relay Latching	Off		Off / On	
Alarm 2 Relay Energised	Off		Off / On	
Alarm 2 Relay Activation Delay	0	seconds	0	1800
Alarm 2 Relay Run On Timer	0	seconds	0	1800
Alarm 2 Activate on Fault	No		Off / On	

SYSTEM SETUP

GASMONITOR

Inside the panel at the top of the rear PCB there are three buttons for use during Setup and Commissioning. The main functions include:

- **ENGINEER** Gas Valve / Pressure fault diagnosis, and Tightness Test.
- **LEARN** Setup and View connected Gas Sensors.
- **INTERROGATE** View system status and Fault Log.

Press the **↑ / ENTER / ↓** buttons on the front of the panel to navigate menus.

ENGINEER

The ENGINEER button can be used to allow system testing, without setting off any alarm relays and any connected audible/visual alarms or shutting down the gas supply.

Any other alarms will override the engineer mode, causing the panel to shut off the gas supply and deactivate the alarm relay.

When Engineer Mode is active, a 30 minute countdown will display, after which the panel will return to normal operation.



Alarm 1

Will display the "Alarm Level 1" along with the associated channel number, and a live gas concentration.



Alarm 2

Will display the "Alarm Level 2" along with the associated channel number, and a live gas concentration



INTERROGATE (DATALOGGING)

The panel has Alarm datalogging included as standard, and will store the most recent 50 alarm events, each with a Date and Time stamp, with a real time clock based on Coordinated Universal Time (UTC) that is maintained by the CR2032 battery in the event of loss of power.

The datalogging and system status menu can be entered one of two ways:

- Pressing the INTERROGATE button
- Holding the TEST button whilst the gas is live.

1. Shows Date & Time.

To update, connect to the Flamefast Connect App or Press Enter to adjust locally.



When factory set, the time will always display in Coordinated Universal Time (UTC). If the time is adjusted in the field, the "(UTC)" indication will no longer be displayed.

2. Provides the live downstream gas pressure and status of all inputs:

OK = Healthy
-- = Alarm



3. Days until a service is due, and if Gas Sensors are installed, days until the soonest sensor is due a calibration and replacement.



4. Alarm Event log with a Date & Time stamp. The description will be as per Line 1 of the display during an alarm condition.



LEARN

Following the installation of any Gas Sensors, they must be paired with the panel, which is done by pressing the LEARN button to enter a menu that will allow the sensors to be viewed and stored into the panel.

Setup

Is used to view and SAVE the number of sensors connected to the panel.

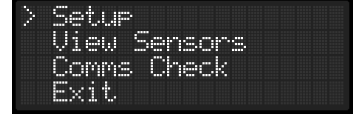

1. Shows the number of Sensors/Repeaters the panel is seeing – if correct, this matches what is installed, select SAVE.
2. Once SAVE is selected, the panel will confirm that the new configuration has been saved.



View Sensors

Overview of what channels are populated, and details of the sensor type and config for each channel.

1. If a sensor channel is populated, the channel number will show in the corresponding position.



Example shown for 7 sensors using channels 1, 2, 3, 4, 9, 11 and 24. Unpopulated channels show as "--".



2. Subsequent displays will show for each channel:

- Channel Number
- Gas Type
- Live Reading
- Unit of Measurement
- Days until Calibration due
- Days until Replacement due.



Comms Check

Performs a sensor comms check. Poor comms can result in nuisance alarms and highlight install issues.

1. Will show which channels are populated as shown in the View Sensors menu.
2. Each channel will briefly display 01 following a read request. If a response is received it will revert back to 00.
3. If a sensor fails to respond, the numbers will count failures, with this screen latching on the peak number of requests.

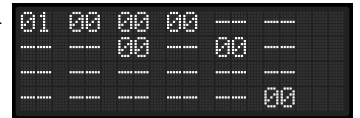
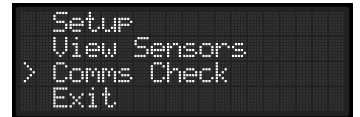

4. Used to adjust the amount of time before the panel flags a “Sensor Not Found” alarm.



TROUBLESHOOTING & MAINTENANCE

GASMONITOR

TROUBLESHOOTING

Any faults can be easily identified due to the clear LCD readout. The following table provides details of all faults including effects and causes:

Display Line 1	Display Line 2	Interface	Cause	Isolates Gas
Previous Power Loss			Previous interruption in mains supply	-
Previous Fire Alarm			Previous Fire Alarm (following Auto-reset)	-
Fire Alarm Active	Please Reset	Fire Alarm	Fire Alarm interface open circuit	✓
Remote Stop Pressed	Please Reset	Remote Stop	Remote Stop interface open circuit	✓
Panel Stop Pressed		Panel Stop	Panel Stop pressed	✓
Thermal Fuse Active	Check Appliance	Thermal Fuse	Thermal Fuse interface open circuit	✓
Ventilation Failure	Check Operation	Ventilation	Ventilation interface open circuit	✓
New Sensor Added	Press LEARN to Setup	Gas Sensor	FGD/FGS – New sensor found on network	✓
Sensor Not Found	Call Manufacturer	Gas Sensor	FGD/FGS – Sensor lost on network	✓
Sensor Error	Call Manufacturer	Gas Sensor	FGD/FGS – Sensor Error	✓
Calibration Due	Call Manufacturer	Gas Sensor	FGD/FGS – Sensor Calibration Due within 30 days	-
New Sensor Required	Call Manufacturer	Gas Sensor	FGD/FGS – Sensor requires replacement within 30 days	-
Replace Sensor	Call Manufacturer	Gas Sensor	FGD/FGS – Sensor requires immediate replacement	✓
Alarm Level 1	Channel XX	Gas Sensor	FGD/FGS – Sensor in Alarm 1 condition	-
Alarm Level 2	Channel XX	Gas Sensor	FGD/FGS – Sensor in Alarm 2 condition	✓

GAS SENSORS

Prior to connection of any gas sensors, ensure that each core (24V, 0V, A and B) is independent, and there is no external or induced voltage as this can cause data corruption, and in some cases, irreparable damage to the sensor.

Any damaged sensors or address conflicts may result in multiple sensors not displaying on the system, including those that are otherwise functioning.

GAS VALVE OUTPUT

If the panel appears to be operating correctly but there is no output to the Gas Valve, check that the PCB mounted radial fuse is still intact. This is located just above the mains in terminals (see wiring diagram for details).

LCD

If the LCD is displaying random characters (as below) there has been a breakdown in communication between the Main PCB and the LCD. There are a number of ways to reset the display when this occurs:



1. Power cycle panel at fused spur.
2. Press INTERROGATE button.
3. Whilst the gas is live, hold the TEST button for 5 seconds.

The display will also automatically refresh itself at 6am and 6pm daily.

MAINTENANCE

The system requires a safety check at least annually to ensure the correct operation of the panel and all associated interlocks.

All connected gas sensors should be bump tested following installation and calibrated at least annually.

This should be carried out by a FLAMEFAST APPROVED ENGINEER.

A service shall be by a Gas Safe Registered Engineer as tightness and let-by test must be performed to prove the correct operation of the solenoid valve.